

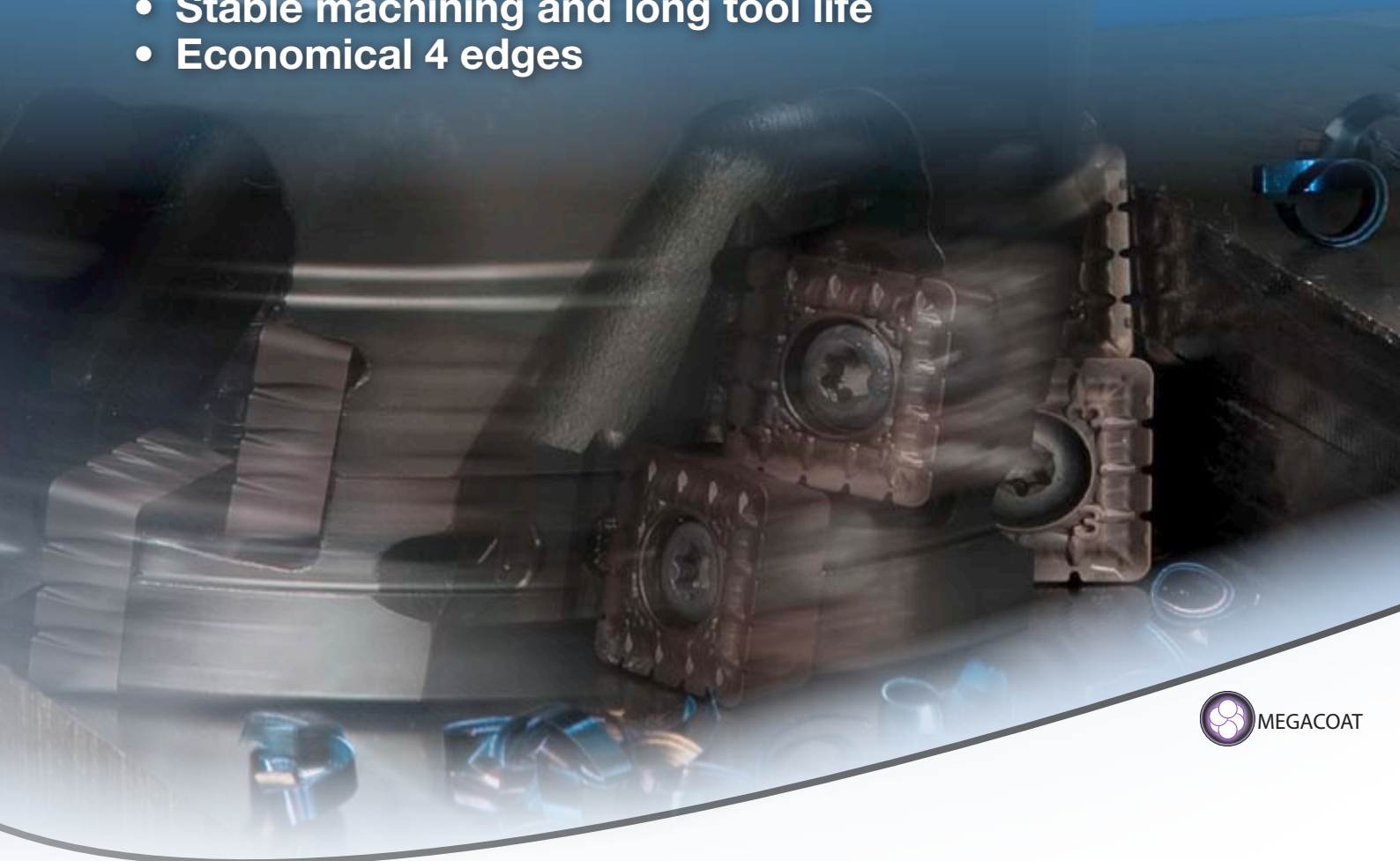

MSRS90

90° Milling Cutter with notched inserts

- Low cutting force and less vibration
- Stable machining and long tool life
- Economical 4 edges



Fraise à 90° avec plaquette rainuré

- Faible effort de coupe et moins de vibration.
- Usinage stable et longue durée de vie outil.
- Economique 4 arêtes.

Fresa a 90° con Tecnologia Notch

- Bassi sforzi di taglio e meno vibrazioni.
- Fresature stabili e lunga durata della vita utensile.
- Economia a 4 taglienti.

Fresa de 90° con insertos de muecas

- Baja fuerza de corte y menos vibracion.
- Mecanizado estable y larga vida de la herramienta.
- 4 lados de corte economico.

■ Low cutting force, less vibration and smooth chip evacuation

Faible effort de coupe, Faible vibration et évacuation des copeaux douce
 Bassi sforzi di taglio , meno vibrazioni ed evacuazione del truciolo regolare
 Baja fuerza de corte, menos vibración y evacuación de viruta sin problemas

- Max. depth of cut 60mm by up to 4-stage
 Max Hauteur de coupe 60 mm avec 4 rangées de plaquettes
 Massima profondità di taglio 60mm ottenibile dall'uso dei 4-moduli
 Maxima profundidad de 60 mm hasta en 4 etapas

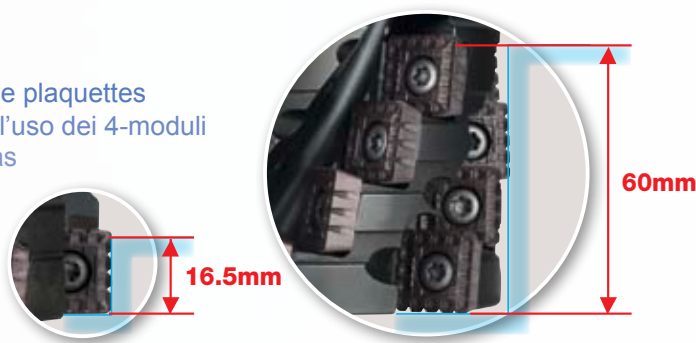

■ High efficiency by notched insert

Haute efficacité avec les rainures sur les plaquettes
 Alta efficienza per mezzo degli inserti con le nicchie
 Insertos de muelas con alta eficacia

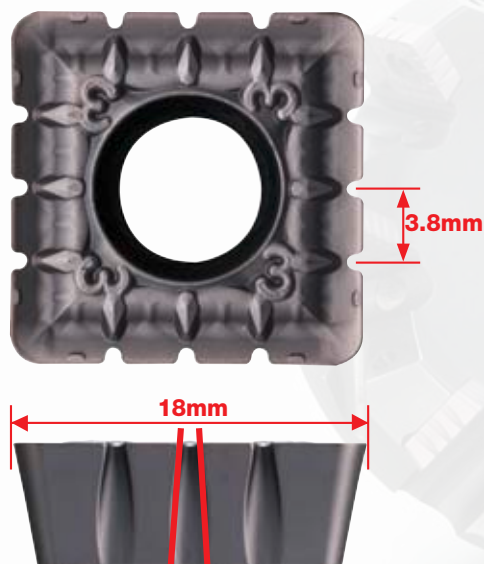

Notched insert breaks chips into small pieces and reduces cutting force.

Les rainures sur les plaquettes permettent de fragmenter les copeaux et de réduire les efforts de coupe.

Gli inserti con le nicchie spezzano il truciolo in piccole dimensioni riducendo gli sforzi di taglio.

Los insertos de muelas rompe la viruta en pequeños trozos y reduce la fuerza de corte.

Second land improves the cutting edge strength.

La deuxième partie de l'arête de coupe est renforcée.

La seconda fase migliora la robustezza del tagliente.

La segunda fase mejora la Resistencia de el lado de corte.

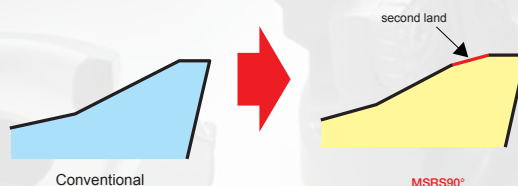

Edge preparation
 Préparation d'arête
 Preparazione tagliente
 Lado de corte preparado

- Comp. of cutting force | Comp. des forces de coupe | Conf. delle forze di taglio | Comp. de la fuerza de corte

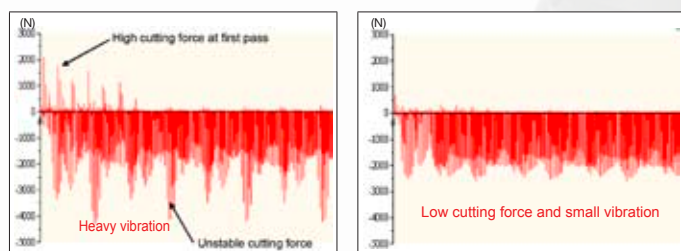







Competitor A

MSRS90

Notched insert realizes low cutting force and small vibration.
 Les plaquettes notched permettent des faibles effort de coupe et de vibration.
 Gli inserti intagliati consentono bassi sforzi di taglio e minori vibrazioni.
 Los insertos con ranuras en los filos, producen menores esfuerzos de corte y vibraciones.

■ Applicable Inserts
 Plaque possible
 Inserti applicabili
 Insertos Aplicables

	3 notches		4 notches		Without notch
General purpose - 1st Recommendation Usage général - 1st Recommendation Usa generico - 1a scelta De uso General - 1 Recomendacion	 NB3	+	 NB4		
Low cutting force Faible effort de coupe Bassi sforzi di taglio Baja fuerza de corte	 NB3P	+	 NB4P		
Emphasis on edge strength Solidité de l'arête Soluzione più robusta Enfasis en la Resistencia de los lados de corte	( NB3	or	 NB4)	+	

Long tool life with MEGACOAT
 Longue durée de vie avec le revêtement MEGACOAT
 Vita utensile lunga con MEGACOAT
 Larga vida de la herramienta con MEGACOAT

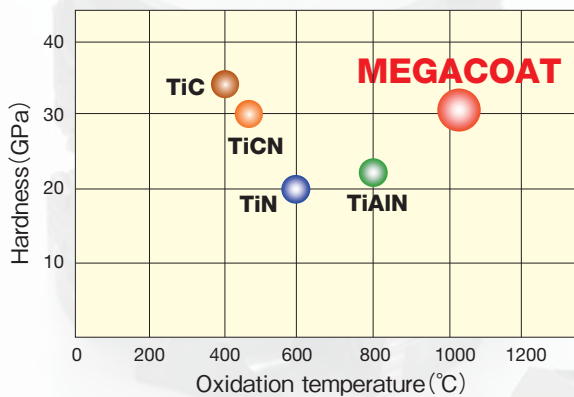

High fracture resistance
 Haute resistance à la fracture
 Alta resistenza alla frattura
 Resistencia a la rotura

Superior heat resistance and hardness
 Resistance à la chaleur et dureté supérieure
 Resistenza superiore al calore ed alla durezza
 Resistencia superior al calor y la dureza

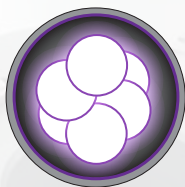

MEGACOAT

Insert Grades MEGACOAT (PVD coated carbide)	Workpiece Material
PR1230	Steel
PR1210	Cast Iron



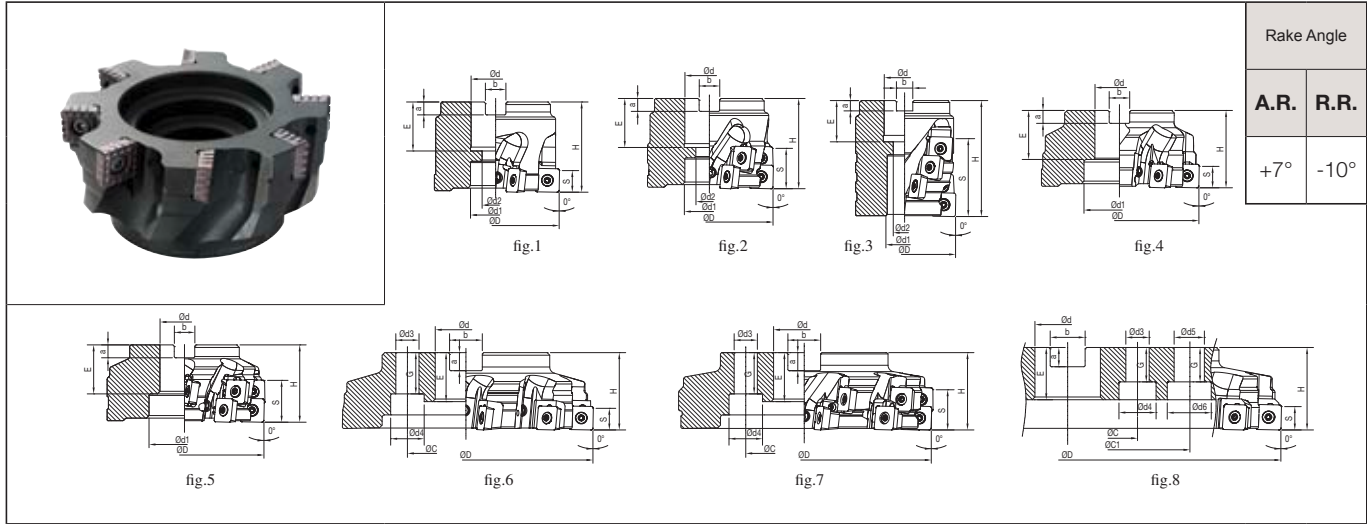







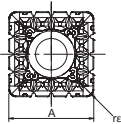

● Holder Dimension

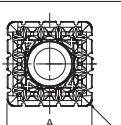
Description	Stanadrd	No. of Insert	No. of Flute	No. of Stage	Dimension(mm)																Shape	(kg) Weight
					øD	ød	ød1	ød2	H	E	a	b	S	ød3	ød4	ød5	ød6	G				
Bore ød:mm	Without Cartridge	MSRS 90080R-1-4T-M	●	4	4	1	80	27	20	13	60	24	7	12.4	16.5	-	-	-	-	-	fig.1	1.4
		90080R-2-4T-M	●	8	4	2									31						fig.2	1.2
		90080R-4-4T-M	●	16	4	4									60						fig.3	1.5
		90100R-1-6T-M	●	6	6	1									16.5						fig.1	2.3
		90100R-2-6T-M	●	12	6	2	100	32	45	-	60	30	8	14.4	31						fig.2	2.1
		90100R-4-6T-M	○	24	6	4	90	60	fig.3	3.2												
		90125R-1-8T-M	●	8	8	1	125	40	55	-	60	33	9.4	16.4	16.5						fig.4	2.6
		90125R-2-8T-M	○	16	8	2	31	fig.5	2.4													
	With Cartridge	MSRS 90160R-1-8T-M	●	8	8	1	160	60	70	-	60	33	9.4	16.4	16.5	fig.4	4.3					
		90160R-2-8T-M	○	16	8	2	31	fig.5	4.1													
		90200R-1-10T-M	●	10	10	1	200	60	-	-	60	38	15	25.9	16.5	fig.6	6.7					
		90200R-2-10T-M	○	20	10	2	31	fig.7	6.6													
		90250R-1-12T-M	●	12	12	1	250	60	-	-	60	38	15	25.9	16.5	fig.6	12.6					
		90250R-2-12T-M	○	24	12	2	31	fig.7	12.5													
90315R-1-14T-M	●	14	14	1	315	60	-	-	60	38	15	25.9	16.5	17	27	22	32	25	fig.8	16.1		
90315R-2-14T-M	○	28	14	2	31	-	-	60	38	15	25.9	16.5	17	27	22	32	25	-	16.0			
Bore ød:inch	Without Cartridge	MSRS 90080R-1-4T	●	4	4	1	80	31.75	27	18	60	32	8	12.7	16.5	-	-	-	-	-	fig.1	1.3
		90080R-2-4T	●	8	4	2									31						fig.2	1.1
		90080R-4-4T	●	16	4	4									60						fig.3	1.4
		90100R-1-6T	●	6	6	1									16.5						fig.1	2.2
		90100R-2-6T	●	12	6	2	100	38.1	39	21	70	38	10	15.9	31						fig.2	2.0
		90100R-4-6T	○	24	6	4	90	60	fig.3	3.1												
		90125R-1-8T	●	8	8	1	125	38.1	55	-	60	38	10	15.9	16.5						fig.4	2.6
		90125R-2-8T	○	16	8	2	31	fig.5	2.4													
	With Cartridge	MSRS 90160R-1-8T	●	8	8	1	160	50.8	70	-	60	38	11	19.1	16.5	fig.4	4.2					
		90160R-2-8T	○	16	8	2	31	fig.5	4.0													
		90200R-1-10T	●	10	10	1	200	47.625	-	-	60	38	14	25.4	16.5	fig.6	6.7					
		90200R-2-10T	○	20	10	2	31	fig.7	6.6													
		90250R-1-12T	●	12	12	1	250	47.625	-	-	60	38	14	25.4	16.5	fig.6	12.6					
		90250R-2-12T	○	24	12	2	31	fig.7	12.5													
90315R-1-14T	●	14	14	1	315	47.625	-	-	60	38	14	25.4	16.5	17	27	22	32	25	fig.8	16.1		
90315R-2-14T	○	28	14	2	31	-	-	60	38	14	25.4	16.5	17	27	22	32	25	-	16.0			

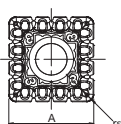
●: Standard Item ○: Made to Order

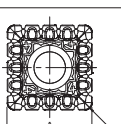
● Applicable Insert

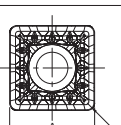
Shape		Description	Dimension(mm)				Angle(°)	MEGACOAT carbide	
			A	T	ød	rε	α	PR1230	PR1210
		SPMT 180616EN-NB3	18	6.35	6.8	1.6	11°	●	●
3 notches								●	●
		SPMT 180616EN-NB4						●	●
4 notches								●	●
		SPMT 180616EN-NB3P	18	6.35	6.8	1.6	11°	●	●
3 notches Low resistance type								●	●
		SPMT 180616EN-NB4P						●	●
4 notches Low resistance type								●	●
		SPMT 180616EN-V	18	6.35	6.8	1.6	11°	●	●
Without notch								●	●







●:Standard Item

● Caution when installing notched Insert

It is important to install the notched insert in the correct position. In case it's installed wrongly the cutter may be damaged. The appropriate insert position is marked on the pocket of the cutter body.

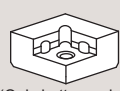
Description	No. of Insert	No. of Flute	No. of Stage	No. of Inserts	
				Notched	
				NB3(P)	NB4(P)
MSRS 90100R-1-6T	6	6	1	3	3
90100R-2-6T	12		2	6	6
90100R-4-6T	24		4	12	12

● Spare parts

Description		Spare Parts											
		Clamp Screw	Wrench	Cartridge	Clamp Screw	Wrench	Anti-seize Compound	Arbor Clamp Screw					
				 (Only bottom edge should be used)									
Without Cartridge	MSRS 90080R-○-4T-M	SB-60120TR	TT-25L	-	-	-	MP-1	HH12×35					
	MSRS 90100R-○-6T-M							-					
	MSRS 90125R-○-8T-M							-					
With Cartridge	MSRS 90160R-○-8T-M							MAP-1806S *2				-	
	90315R-○-14T-M							3.5Nm for cartridge clamp tightening torque					
Without Cartridge	MSRS 90080R-○-4T							7.5Nm for insert clamp tightening torque	-	-	-	-	MP-1
	MSRS 90100R-○-6T	-											
	MSRS 90125R-○-8T	-											
With Cartridge	MSRS 90160R-○-8T	MAP-1806M *1 MAP-1806S *2	SB-40140TR	DT-15									
	90315R-○-14T	3.5Nm for cartridge clamp tightening torque											

Note) *1: MAP-1806M is only for MSR90..R-1..cartridge

*2: MAP-1806S is only for MSR90..R-2..bottom edge (1st stage) cartridge. This cartridge is used for bottom edge (1st stage) only.

How to attach cartridge: To fix the cartridge, tighten the slant screw at first, then tighten the other screw.



Coat Anti-seize Compound (MP-1) thinly on clamp screw when insert is fixed.

■ Recommended Cutting Conditions
 Conditions de coupe recommandée
 Parametri di Taglio Consigliati
 Condiciones de corte recomendadas

Workpiece Material	fz (mm/t)		Vc (m/min)	
	1st Choice Standard NB3+NB4	Low Cutting Force NB3P+NB4P	MEGACOAT Carbide	
			PR1230	PR1210
Soft Steel	0.1~ 0.2 ~0.25	0.1~ 0.2 ~0.25	120~ ★150 ~220	120~ ☆150 ~220
Carbon Steel	0.1~ 0.2 ~0.25	0.1~ 0.2 ~0.25	100~ ★150 ~200	100~ ☆150 ~200
Alloy Steel	0.1~ 0.15 ~0.2	0.1~ 0.15 ~0.2	100~ ★150 ~200	100~ ☆150 ~200
Die Steel	0.1~ 0.15 ~0.2	0.1~ 0.12 ~0.15	100~ ★150 ~180	100~ ☆150 ~180
Gray Cast Iron	0.1~ 0.2 ~0.3	0.1~ 0.2 ~0.25	100~ ☆180 ~250	100~ ★180 ~250
Nodular Cast Iron	0.1~ 0.2 ~0.25	0.1~ 0.18 ~0.2	100~ ☆180 ~220	100~ ★180 ~220

★:1st Recommendation ☆:2nd Recommendation

● MSRS90100R-1-6T

(Shouldering)

Workpiece Material	Overhang Length (mm)	Vc (m/min)	fz (mm/t)	apxae (mm)	Chip Removal Rate (cc/min)
Carbon Steel	<100	150	0.2	15x80	688
	100-200	150	0.2	15x40	344
	201<	200	0.1	15x40	229
Cast Iron	<100	180	0.2	15x80	825
	100-200	180	0.2	15x40	413
	201<	230	0.1	15x40	264

● MSRS90100R-2-6T

(Shouldering)

Workpiece Material	Overhang Length (mm)	Vc (m/min)	fz (mm/t)	apxae (mm)	Chip Removal Rate (cc/min)
Carbon Steel	<100	150	0.2	30x50	859
	100-200	150	0.2	30x30	516
	201<	200	0.1	30x25	286
Cast Iron	<100	180	0.2	30x50	1031
	100-200	180	0.2	30x30	619
	201<	230	0.1	30x25	329

● MSRS90100R-4-6T

(Shouldering)

Workpiece Material	Overhang Length (mm)	Vc (m/min)	fz (mm/t)	apxae (mm)	Chip Removal Rate (cc/min)
Carbon Steel	<100	150	0.2	60x20	688
	100-200	150	0.2	60x10	344
	201<	200	0.1	60x10	229
Cast Iron	<100	180	0.2	60x20	825
	100-200	180	0.2	60x10	413
	201<	230	0.1	60x10	264

Note) Slotting is not recommended.

MSRS90



■ Examples of Tailor Made Cutters
 Exemple d'outils spéciaux
 Esempio di frese Taylor Made
 Ejemplos de corte hecho a medida

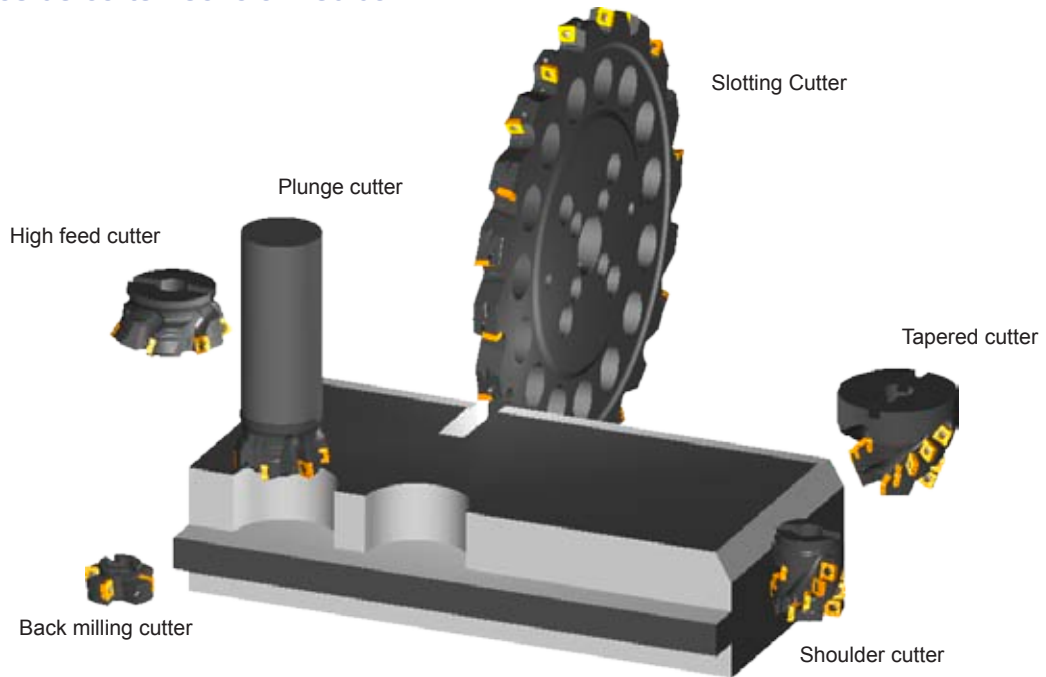

● Shaft machining | Usinage de vilebrequin | Fresatura albero a gomiti e simili | Eje de mecanizado



Face mill
Left hand

Face mill
Right hand



High feed cutter



45 degrees face mill



Plunge cutter



Tapered cutter



Slotting cutter

Various types of cutter design available to meet your requirements, such as cutting diameter, cutting angle and cutting edge length (stages), etc.

Case studies

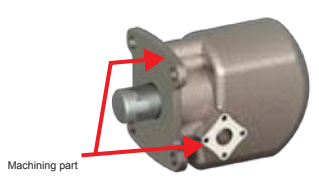
GGG45	
Industrial parts Cutter and inserts MSRS90100R-1-6T SPMT180616EN-NB3/NB4 (PR1210) $V_c=150$ m/min $a_p \times a_e=6 \times 65$ mm $f_z=0.15$ mm/t (Vf=430mm/min)	
MSRS90(PR1210)	Chip removal 258cc/min.
Competitor B	107cc/min.
Results · MSRS90 doubled the cutting efficiency compared to competitor B. · Comp. B machined with 2 passes ($a_{pxae}=3 \times 65$ mm). MSRS90 machined with only 1 pass. · Cutting time reduced.	
Evaluation by the user	

20CrMo4	
Construction machine parts Cutter and inserts MSRS90125R-1-8T SPMT180616EN-NB3/NB4 (PR1230) $V_c=200$ m/min $a_p \times a_e=10 \times 50$ mm $f_z=0.1$ mm/t (Vf=400mm/min)	
MSRS90(PR1230)	Chip removal 200cc/min.
Competitor C	153cc/min.
Results · MSRS90 improved cutting efficiency to 1.3 times compared to competitor. C. · Comp. C: $a_{pxae}=5 \times 50$ mm · Tool cost reduced to 1/3 since comp. C is 2-cornered insert. MSRS90 reduced machining cost as well as improving cutting efficiency.	
Evaluation by the user	

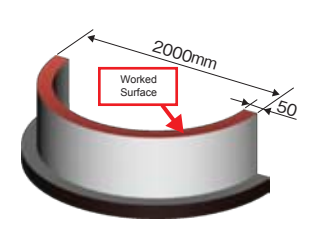
Tool Steel (HRC28)	
Ship parts Cutter and inserts MSRS90160R-1-8T SPMT180616EN-NB3/NB4 (PR1230) $V_c=150$ m/min $a_p \times a_e=10 \times 10 \sim 50$ mm $f_z=0.1$ mm/t (Vf=240mm/min)	
MSRS90(PR1230)	Chip removal 120cc/min.
Competitor D	60cc/min.
Results · MSRS90 doubled the cutting efficiency compared with competitor D. · Comp. D: $a_{pxae}=5 \times 10 \sim 50$ mm, MSRS90 can increase a_p twice due to low cutting force. · MSRS90 can increase a_p as well as cutting speed ($V_c=150$). It resulted in total cutting efficiency improvement. (time reduction)	
Evaluation by the user	

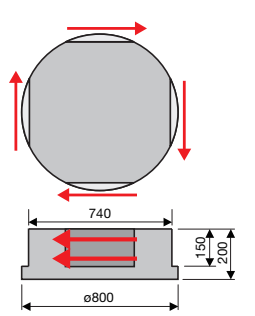
Alloyed Construction Steel	
Power generator parts Cutter and inserts MSRS90125R-1-8T SPMT180616EN-NB3/NB4 (PR1230) $V_c=160$ m/min $a_p \times a_e=10 \times 0 \sim 20$ mm $f_z=0.15$ mm/t (Vf=500mm/min)	
MSRS90(PR1230)	12 faces / edge
Competitor E	8 faces / edge
Results · MSRS90 improved tool life to 1.5 times of competitor E. · Comp. E machined with 2 pass ($a_{pxae}=12 \times 0 \sim 10$ mm) with low cutting feed ($V_f=400$ mm/min). MSRS90 improved cutting efficiency. (time reduction) · Comp. E creates large noise due to large cutting force. MSRS90 reduced the cutting force and noise as well.	
Evaluation by the user	



KYOCERA Fineceramics GmbH
 Cutting Tool Division
 Hamnrieddamm 6, 41460 Neuss, Germany
 Phone: +49 (0) 2131 1637-115
 Fax: +49 (0) 2131 1637-152
 www.kyocera.de / www.kyocera.eu
 ceratip@kyocera.de

KYOCERA Fineceramics SAS.
 Cutting Tool Division
 4, allee du Commandant Mouchotte
 Paray-vieille-poste 91781, Wissous Cedex, France
 Phone: +33 (0) 1 45 12 06 93 Fax: +33 (0) 1 56 72 18 94
 www.kyocera.fr

KYOCERA Fineceramics GmbH sp. z o.o. Poland Branch Office
 Cutting Tool Division
 Leg. ul. Europejska 4, 55-220, Jelcz-Laskowice, Poland
 Phone: +48-(0) 71-381-12-15 Fax: +48-(0) 71-381-12-16
 www.kyocera.eu

KYOCERA Fineceramics GmbH Italy Branch Office
 Cutting Tool Division
 Via Torino 51, 20123 Milan, Italy
 Phone: +39-02 00620 845 Fax: +39-02 00620 848
 www.kyocera.it

KYOCERA Fineceramics GmbH Spain Branch Office
 Cutting Tool Division
 Avenida Manacor 4, 28290 Las Matas, Madrid, Spain
 Phone: +34-91-631-83-92-802 Fax: +34-91-631-82-19
 www.kyocera.es